

COOLZONE[®]



**7 Bottle Wine Chiller with Digital Display
CZ51197**

USER INSTRUCTIONS

Please read these instructions carefully before using this product and keep them safe for future reference

Page contents

Parts identification

Check the contents	2
Before use	2
Parts identification	2
Do and Don't	2
Installation	3
Using the chiller	3
Door reversal	4
Maintenance and cleaning	5
Fuse and mains plug replacement	5
Specification	6
Safety measures and disposal	6
After sales service	6

1. Control Panel with LED display
2. Wine racks x 5
3. Door

Before use

Packaging

The packaging is recyclable so dispose of it according to local regulations. Keep the packaging materials out of reach of young children.

Warning

Care is needed when unpacking and moving the chiller. Hold it by the casing – not the door or trim.

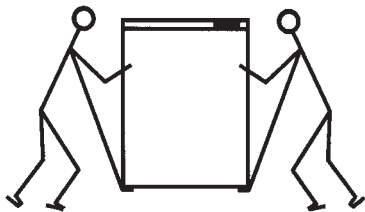
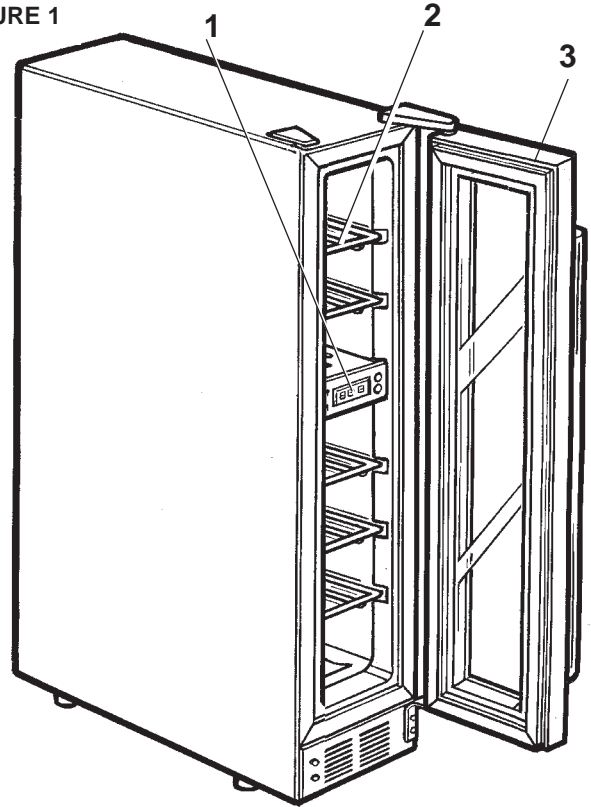

FIGURE 1



Check the contents

After unpacking, wipe the casing with a dry cloth and clean the inside with a damp cloth ready for use.

Check the following contents are included with the product and inspect the casing for any damage. If there is any damage, contact the retailer from whom you purchased the product.

- Wine racks x 5
- Plastic feet x 4

Do and don't

- ❖ Do read these instructions thoroughly before using this appliance.
- ❖ Do install the appliance only in the vertical position.
- ❖ Do install to allow for adequate ventilation around the appliance.
- ❖ Do unplug before cleaning and maintenance.
- ❖ Only use it in accordance with the manufacturer's instructions.
- ❖ Don't install the appliance in humid or extreme conditions.
- ❖ Don't attempt to repair the appliance yourself – (see Helpline information – page 6).
- ❖ Don't store goods containing inflammable or other explosive gases.
- ❖ Don't leave door closed if appliance is left switched off for long periods.
- ❖ Don't install near heaters or other heat sources.

Installation

Important

Make sure that the voltage marked on the rating label on the product corresponds with the voltage in your home.

This quality product has been tested and certified to meet all applicable UK electrical and safety standards.

If not already fitted, screw the feet into the bottom of the cabinet.

The cooler must be installed on a firm flat and level surface. The feet are adjustable to level the appliance.

The appliance is designed to operate at normal room temperatures. Position it away from any heat source such as a boiler, oven and heater. It is also not advisable to install the appliance in unheated locations, such as garages or outbuildings, as these will impair the operation of the chiller in winter.

The cooler requires space around the casing for ventilation and heat dissipation.

Allow adequate space at the rear of the chiller and do not obstruct any ventilation vents and slots.

Switching on

Plug the cooler into a nearby power socket and switch the socket to ON.

The interior temperature of the chiller will show on the control panel display. A fan noise will indicate that the chiller is running.

Interior light

The interior LED light can be turned on and off by pressing the Light button. The LEDs are not replaceable.

Using the chiller

Temperature control

To keep your wine in perfect condition the temperature of this chiller can be regulated in steps of one degree Celsius ranging from 8 to 22°C.

Recommended temperatures for wine storage:

Wine type	Temperature
Red wines	15–18°C
Dry/white wines	10–15°C
Sparkling wines	8–9°C

Setting the temperature

To set the chiller to the recommended temperature depending upon the wine type to be stored (see table above), press the 'UP' button to make the chiller warmer, or the 'DOWN' button to make the chiller colder.

The display will continue to flash as you press the button.

When the flashing display shows the temperature you require release the button.

The display will flash several times to show the changed temperature.

To check the set temperature press either the 'UP' or 'DOWN' buttons.

The chiller will maintain the set temperature by switching on and off.

Adjusting display temperature

The display temperature can be changed to display in Degrees Celsius (C) or Fahrenheit (F), by pressing the Temperature Display button - 'C/F'

FIGURE 2

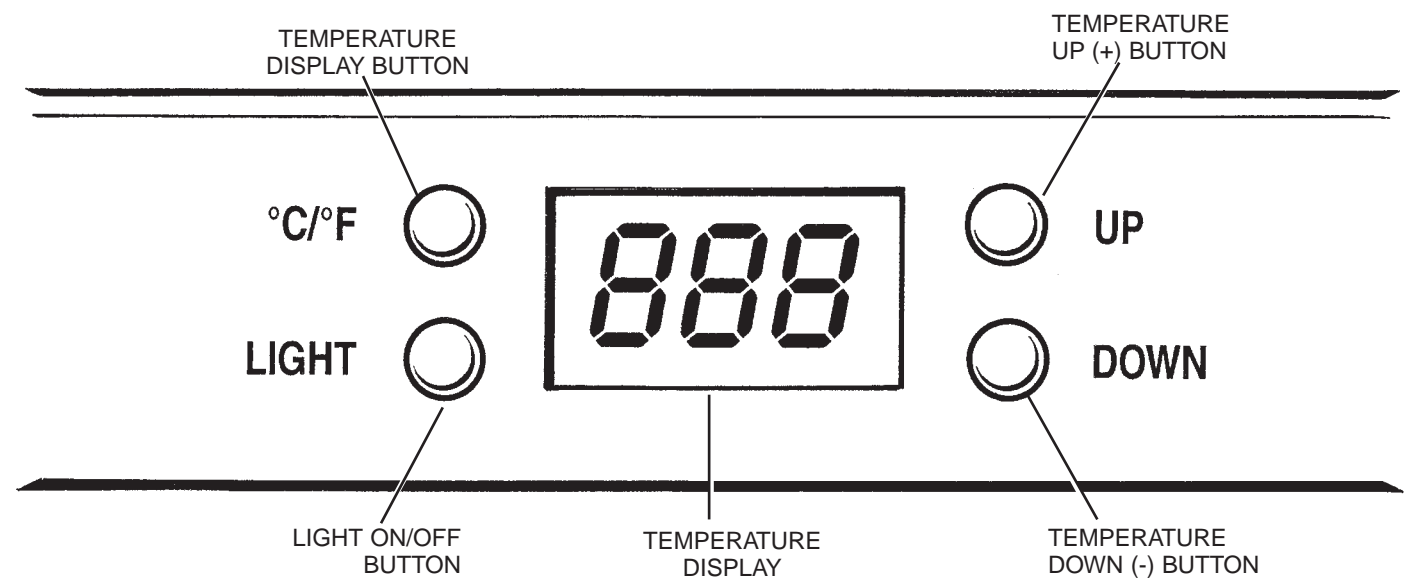

Door reversal

For ease of use, the door of the chiller can be reversed to open from the left or from the right.

Door removal

1. Using a flat screwdriver or suitable tool, gently prise off the hinge plate cover at the top of the unit. (Figure 3).
2. Unscrew the hinge plate and lift it out of its fixing holes. (Figure 3).
3. Using a flat screwdriver or suitable tool, gently prise off the blanking cover, located on the non-hinged side of the chiller. (Figure 4).
4. Support the door on both sides and remove it from its bottom hinge by lifting it upwards and away from the unit. Rest the door in a safe place until it is required.
5. Unscrew the bottom hinge and pull it out of its fixing holes and away from the unit. (Figure 5).

Door replacement or reversal

To replace the door, follow the above instructions in reverse order.

If door reversal is required, replace the hinges at the opposite side from which they were unscrewed.

The door will need to be turned over so that the handle is on the opposite side.

FIGURE 3

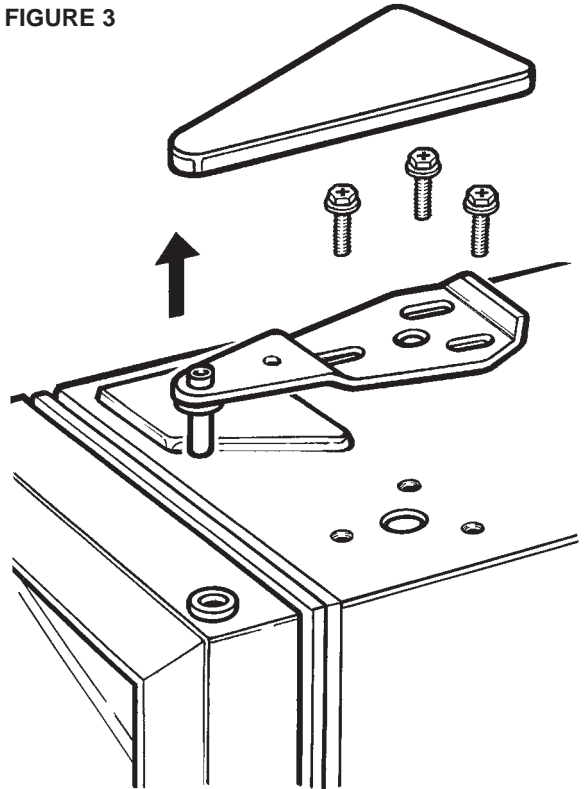

FIGURE 4

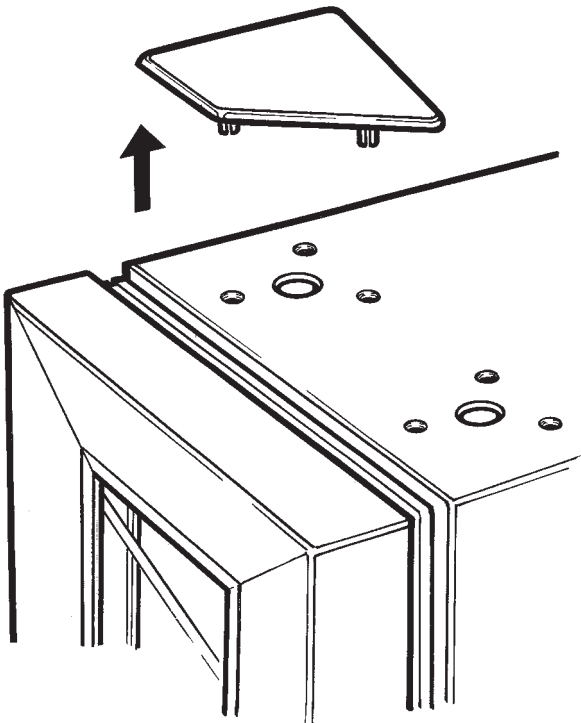
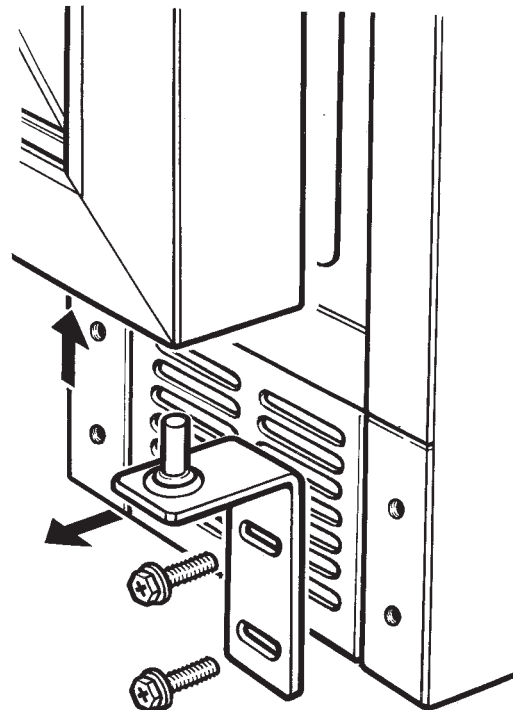

FIGURE 5



Maintenance and cleaning

Once a month wipe the interior surfaces and door seal using a teaspoonful of bicarbonate of soda diluted in a pint of warm water to remove any residues or odours.

The external casing can be cleaned with warm soapy water and protected by polish. Do not use scouring powders which can scratch the surface.

IMPORTANT: The chiller must be turned off at the mains before maintaining or cleaning. It is recommended to clean and wipe out the chiller after any spillage inside or outside the appliance.

If leaving the chiller unused for a prolonged period, unplug from mains, wipe dry and leave the door open.

Fuse and mains plug replacement

This product is supplied with a fitted plug which contains a 3A fuse. If you are simply replacing the fuse, you must use a 3A fuse which has been approved by ASTA to BS1362.

If the plug does not fit the socket or becomes damaged, a new plug must be fitted. Replace the original plug with the correct plug for your socket. If this is a 3-pin (square pin) 13A (BS1363) plug, you must make sure that it is fitted with an ASTA approved 3A fuse.

If another type of plug is used, it must be protected by a 5A fuse, either in the plug or at the distribution board.

FIGURE 6

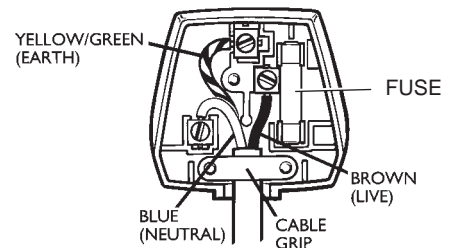

1. Cut off the existing fitted plug.

2. The wires in the mains lead supplied with this appliance are coloured in accordance with the following code (Figure 6):

GREEN/YELLOW = EARTH (E) BLUE = NEUTRAL (N) BROWN = LIVE (L)

This product must be earthed.

As the colours of the wires in the mains lead may not correspond with the colour markings identifying the terminals in your new plug, proceed as follows.

The wire which is coloured GREEN or YELLOW/GREEN must be connected to the terminal which is marked with the letter E or \oplus symbol or coloured GREEN or YELLOW/GREEN.

The wire which is coloured BLUE must be connected to the terminal in the plug which is marked with the letter N or coloured BLACK or BLUE.

The wire which is coloured BROWN must be connected to the terminal which is marked with the letter L or coloured RED or BROWN.

3. Ensure that the connections are tight and that no loose strands are left out of the terminals.

IF IN ANY DOUBT CONSULT A QUALIFIED ELECTRICIAN.

If the mains lead becomes damaged consult a qualified electrician.

Specification

Capacity (litres)	20
Dimensions: HxWxD mm	860x150x560
Power consumption (Watts)	65–70
Power supply	230V~50Hz

Product specification may vary without prior notice.

Safety measures and disposal

Never try to repair the appliance or the electrical parts yourself. Any repair carried out by an unskilled person is dangerous and may affect the guarantee. Contact the Helpline below for assistance and advice.

Disposal of old chiller or fridge

Disposal of the appliance must conform with EU environmental regulations.

Cut off the mains lead and remove any door locks to ensure the appliance is beyond further use.

The appliance must be delivered to an authorised collection centre.



This appliance/fitting is marked according to the European directive 2002/96/EC on Waste Electrical and Electronic Equipment (WEEE). By ensuring this product is disposed of correctly, you will help prevent potential negative consequences for the environment and human health, which could otherwise be caused by inappropriate waste handling of this product.

The symbol on the product, or on the documents accompanying the product, the Crossed Out Wheellie Bin symbol, indicates that this appliance/fitting may not be treated as household waste. Instead it shall be handed over to the applicable collection point for the recycling of electrical and electronic equipment. Disposal must be carried out in accordance with local environmental regulations for waste disposal. For more detailed information about treatment, recovery and recycling of this product, please contact your local authority, your household waste disposal service or the retailer where you purchased the product.

After sales service

This appliance is guaranteed for a period of two years from date of purchase against defects in materials and workmanship only, and provided that all these user instructions have been strictly complied with. The guarantee does not cover incidental or consequential loss, such as loss of consumables.

Where this guarantee applies, the appliance will be repaired or replaced at the manufacturer's option without charge. If the guarantee does not apply or has expired, you will be given a quotation for cost of repairs and any parts required.

Keep your purchase receipt with these instructions, and in the event of breakdown contact the HELPLINE on 0844 871 0011.

For Faults and Assistance
Phone: 0844 871 0011