

COOLZONE[®]

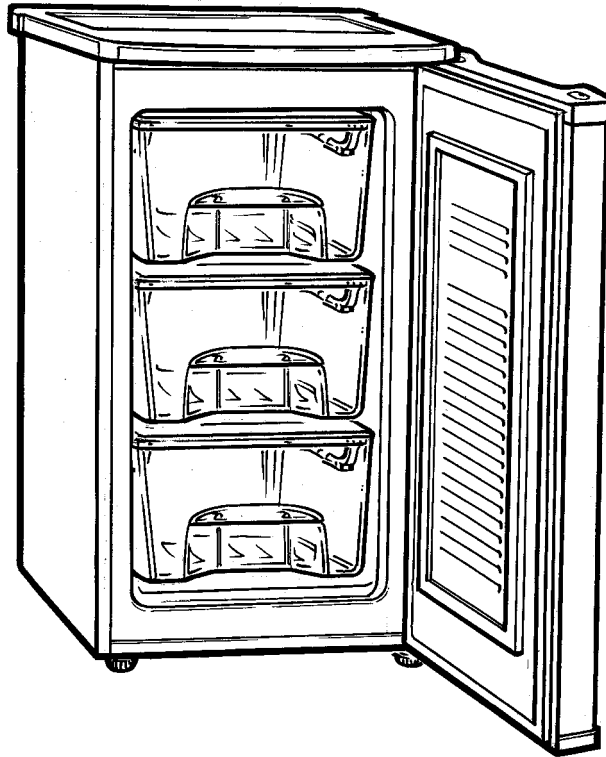

CZ51059Z
Freezer

USER INSTRUCTIONS

Please read these instructions carefully before using this product and keep them safe for future reference.

Page contents

Before use	2
Do and Don't	2
Parts identification	3
Installation and controls	3, 4
Maintenance and cleaning	5
Door reversal	5,6
Troubleshooting	7
Fuse and mains plug replacement	7
Specification	8
After sales service	8
Safety measures and disposal	8

Before Use

Packaging

The packaging is recyclable so dispose of it according to local regulations. Keep the packaging materials out of reach of young children. Before installation take care to remove all cardboard or other packaging, including material from the condenser tubes and any material surrounding the motor/compressor unit.

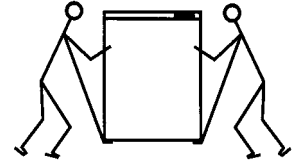

Warning

The fridge is heavy and care is needed when unpacking and moving it. Get extra help and only hold it by the casing – not the door or trim.

Check the contents

Check the following contents are included with the product and inspect the casing for any damage. If necessary contact your retailer from whom you purchased the product.

3 x freezer drawers

After unpacking, wipe the casing with a dry cloth and clean the inside with a damp cloth ready for food storage.

Do and Don't

- ◆ Do read these instructions thoroughly before using this appliance.
- ◆ Do install the appliance only in the vertical position.
- ◆ Do let your freezer stand for 12 hours prior to connection, to allow the cooling gases to stabilise, if transported in a horizontal position.
- ◆ Do install to allow for adequate ventilation around the appliance.
- ◆ Do not install near heaters or other heat sources.
- ◆ Do unplug before cleaning and maintenance.
- ◆ Do freeze fresh food in the freezer compartment. It is a 4-star freezer compartment suitable to store frozen food for 3-12 months.
- ◆ Don't install the appliance in humid or extreme conditions.
- ◆ Don't attempt to repair the appliance yourself (see Helpline information – page 8).
- ◆ This appliance is intended for domestic use only. Only use it in accordance with the manufacturer's instructions.
- ◆ Don't use any other electrical device inside the appliance to defrost.
- ◆ Don't store goods containing inflammable or other explosive gases.
- ◆ Don't leave door closed if appliance is left switched off for long periods.

Parts identification

The parts are listed and numbered below to help identification.

1. Freezer drawers

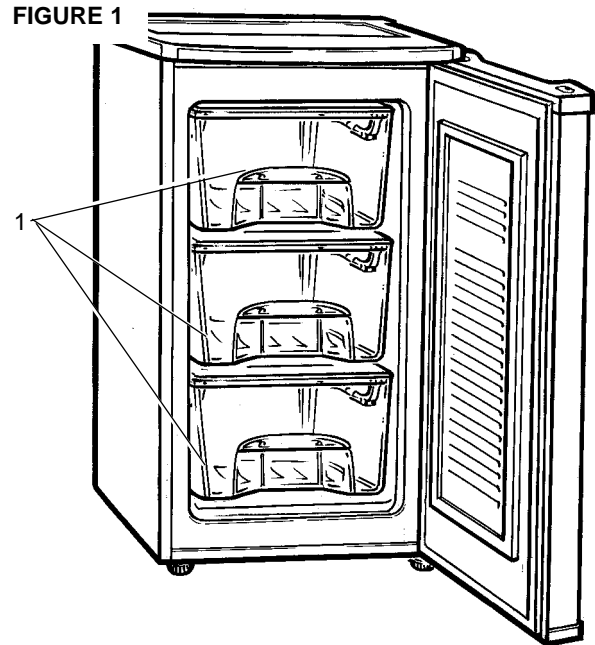

Installation and controls

Important

Make sure that the voltage marked on the rating label on the product corresponds with the voltage in your home.

This quality product has been tested and certified to meet all applicable UK electrical and safety standards.

The appliance is designed to work in room temperatures between +16°C and +32°C. Do not allow the room temperature to exceed +32°C otherwise the temperature inside the freezer will rise.

The freezer requires space around the casing for efficient cooling and operation. The minimum clearances are shown in Figure 2.

There must be at least 100mm clearance between the appliance and the rear wall

The freezer must be installed on a firm flat and level surface for it to work quietly and efficiently.

FIGURE 2

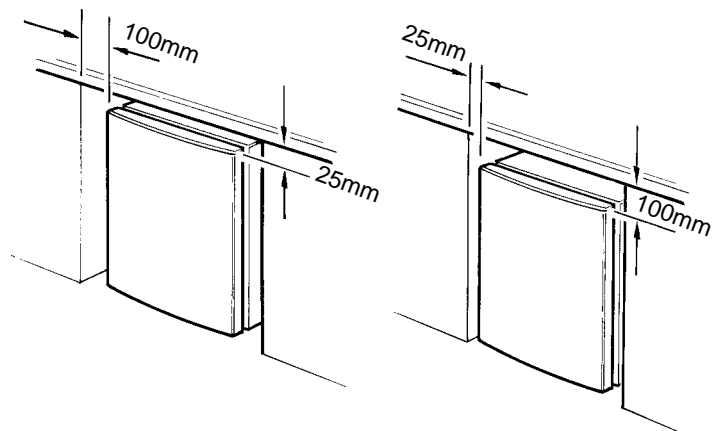

Diagrams show alternative methods of providing correct air flow around the appliance.

Switching on

Plug the appliance into a nearby power socket and switch on. The thermostat control (Figure 3) is at the back of the appliance. Turn the control to the '5' position on the dial and leave the appliance running with the door closed for approximately 2 hours. This will allow the inside temperature to stabilise.

FIGURE 3

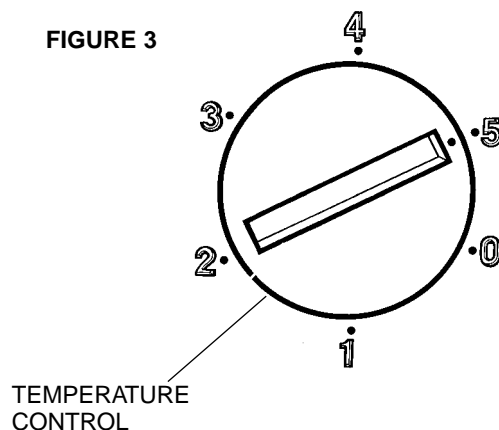

Installation and controls (cont)

Temperature control

The temperature of the freezer is best maintained between -18°C to -24°C. Use of a freezer thermometer (not supplied) is recommended to monitor conditions in the freezer. The 3–4 position is adequate for typical indoor conditions but depending on conditions you may need to set the control anywhere between 1 and 5.

Notes on operation

During normal operation the following noises may be heard:

- ❖ Stifled murmur from compressor when it is working.
- ❖ Soft gurgling from the refrigerant flowing through the cooling system.
- ❖ Click from the thermostat switching on and off.

Using the freezer



Precautions

The freezer is capable of producing very cold temperatures which may cause injury if safety precautions are not observed:

Caution: Do not touch ice with bare skin to avoid 'ice burns'.

- ❖ Do not attempt to freeze carbonated drinks such as fizzy pop, mineral water, champagne etc. as the bottles may break when frozen. Drinks in PEP plastic bottles must not be frozen.
- ❖ The freezer must only be used for the storing of edible foodstuffs.
- ❖ Frozen food that has thawed should not be re-frozen.

Frozen food storage

Food which has been purchased frozen should be kept in its original packaging. Maximum storage times and expiry dates are usually given on the food packaging.

IMPORTANT

Do not re-freeze food that has thawed or partially thawed.

When cooking food you must ensure it has thoroughly thawed, especially important regarding poultry and seafood.

Do not overload the food baskets and always allow space between the packages of food. This ensures that cold air is free to circulate, preventing the food packages from sticking together.

When freezing fresh food do not freeze too much food at one time. Do not exceed 4kg in 24 hours.

When removing ice cubes, it may help to hold the tray under running water for a few seconds in order to loosen the ice.

When freezing hot food allow it to cool before placing it in the freezer. Always store it away from food which is already frozen.

In case of power failure

If there is a power failure do not open the freezer door. Frozen food should not be affected if the failure lasts less than 20 hours. If the failure continues for longer than 20 hours, check the contents of the freezer. Do not re-freeze food that has thawed or partially thawed.

Maintenance and cleaning

Important

The fridge must be turned off at the mains before maintenance or cleaning.

General cleaning

It is recommended to clean and wipe out the freezer regularly or after any spillage inside or outside the appliance.

Use a teaspoonful of bicarbonate of soda diluted in a pint of warm water. Wipe the internal surfaces and shelving to remove food residues. Leave to dry before reloading food.

Wipe the outside casing from time to time in order to remove dirt and dust from ventilation vents etc.

Keep water away from the thermostat housing.

Clean the door seals.

Remove accumulated dirt from around the compressor motor taking care not to damage the pipes and the wiring.

When not in use

If the appliance is to be emptied and turned off for a long period it is advisable to:

- ◆ Disconnect the unit from the mains supply.
- ◆ Empty the freezer of food and allow any ice that has formed to melt.
- ◆ Clean and dry the interior.
- ◆ Leave the door open.

Door reversal

Reversing the door may make installation more convenient. The appliance must be tilted and supported in order to carry this out; it is therefore advisable to get an assistant to help during this procedure. Take care when fitting and tightening screws.

Use a screwdriver to prise off the two blanking plates, and remove the two screws securing the top of the worktop.

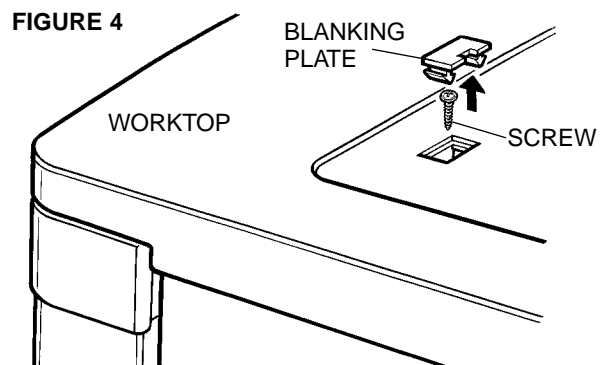

Door reversal (cont)

FIGURE 5

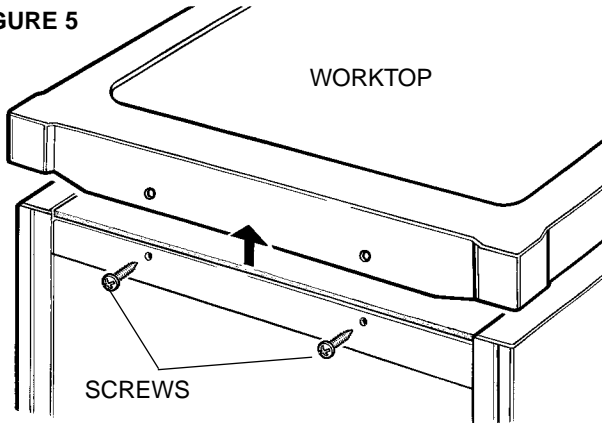

Remove the two screws securing the rear of the worktop.

FIGURE 6

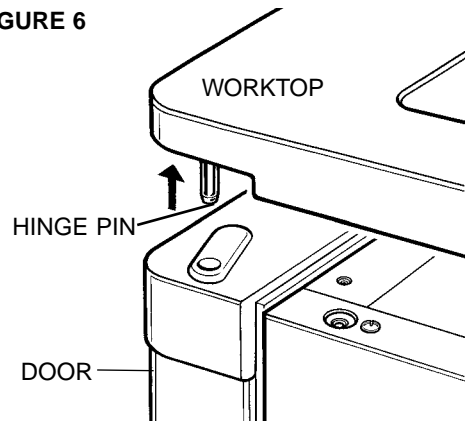

Support the door and lift away the worktop and its attached hinge pin. Remove the door by lifting it upwards.

FIGURE 8

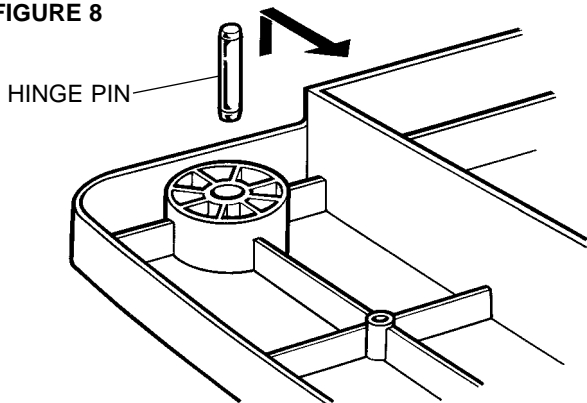

Pull out the hinge pin from the underside of the worktop and refit the pin at the opposite corner.

FIGURE 9

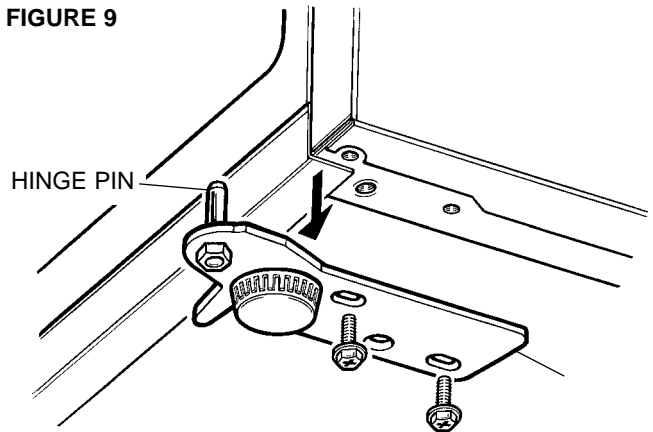

Unscrew the lower hinge from the fridge casing, and refit onto the other side.

LOWER HINGE

FIGURE 10

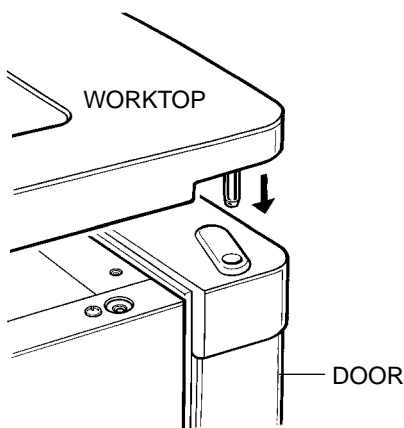

Replace the door by locating it into the lower hinge pin.

Support the door and replace the worktop, with its attached hinge pin located into the door.

Replace all worktop screws and blanking plates.

FIGURE 11

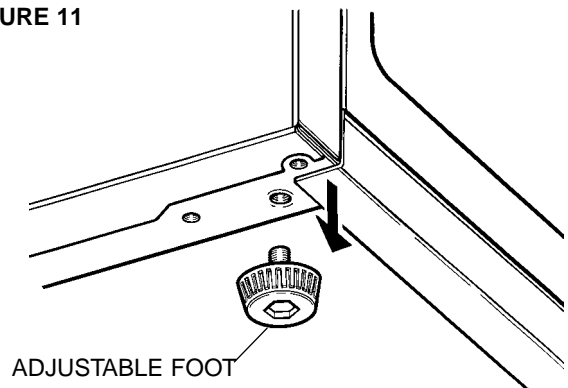

Replace feet and level the appliance.

Troubleshooting

Problem	Possible cause	Remedy
The lamp does not light	The lamp has blown	Replace the lamp with same type: 15W, SES, E14
The motor is on for long periods without switching off	Door opened too often The airflow around the unit is inadequate	Do not open door needlessly Allow more free space around the unit
Motor not working	No power to unit	Check fuses, plug, and power supply
Freezer is not cold enough	Thermostat set too low	Turn to higher setting

Fuse and mains plug replacement

This product is supplied with a fitted plug which contains a 13A fuse. If you are simply replacing the fuse, you must use a 13A fuse which has been approved by ASTA to BS1362 (Figure 12).

If the plug does not fit the socket or becomes damaged, a new plug must be fitted. Replace the original plug with the correct plug for your socket. If this is a 3-pin (square pin) 13A (BS1363) plug, you must make sure that it is fitted with an ASTA approved 13A fuse.

If another type of plug is used, it must be protected by a 15A fuse, either in the plug or at the distribution board.

1. Cut off the existing fitted plug.
2. The wires in the mains lead supplied with this appliance are coloured in accordance with the following code (Figure 13):
GREEN/YELLOW = EARTH (E)
BLUE = NEUTRAL (N) BROWN = LIVE (L)

This product must be earthed

As the colours of the wires in the mains lead may not correspond with the colour markings identifying the terminals in your new plug, proceed as follows.

The wire which is coloured GREEN or YELLOW/GREEN must be connected to the terminal which is marked with the letter E or \oplus symbol or coloured GREEN or YELLOW/GREEN.

FIGURE 12

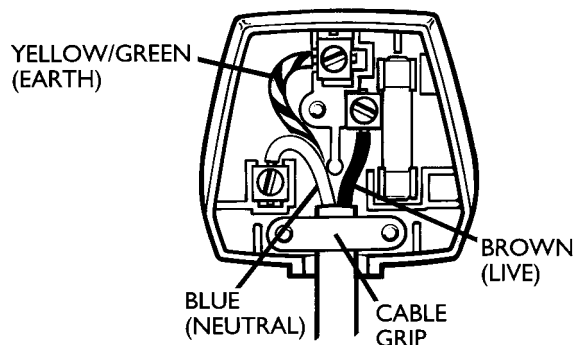

The wire which is coloured BLUE must be connected to the terminal in the plug which is marked with the letter N or coloured BLACK or BLUE.

The wire which is coloured BROWN must be connected to the terminal which is marked with the letter L or coloured RED or BROWN.

3. Ensure that the connections are tight and that no loose strands are left out of the terminals.

IF IN ANY DOUBT CONSULT A QUALIFIED ELECTRICIAN.

If the mains lead becomes damaged consult a qualified electrician.

Specification

Total net volume (litres)	70
Dimensions: HxWxD mm	850x480x495
Power supply	220/240V, 50Hz
Energy efficiency class	A
Refrigerant	R600a

Product specification may vary without prior notice.

After sales service

This appliance is guaranteed for a period of two years from date of purchase against defects in materials and workmanship only, and provided that all these user instructions have been strictly complied with. The guarantee does not cover incidental or consequential loss, such as loss of consumables.

Where this guarantee applies, the appliance will be repaired or replaced at the manufacturer's option without charge. If the guarantee does not apply or has expired, you will be given a quotation for cost of repairs and any parts required.

Keep your purchase receipt with these instructions, and in the event of breakdown contact the HELPLINE on 0844 871 0011.

Safety measures and disposal

Never try to repair the appliance or the electrical parts yourself. Any repair carried out by an unskilled person is dangerous and may affect the guarantee. Contact the Helpline for assistance and advice.

Disposal of old fridge

Disposal of the appliance must conform with EU environmental regulations.

Make the appliance not usable by cutting off the mains lead and removing any door locks.

The appliance must be delivered to an authorised collection centre.



This appliance/fitting is marked according to the European directive 2002/96/EC on Waste Electrical and Electronic Equipment (WEEE). By ensuring this product is disposed of correctly, you will help prevent potential negative consequences for the environment and human health, which could otherwise be caused by inappropriate waste handling of this product.

The symbol on the product, or on the documents accompanying the product, the Crossed Out Wheelie Bin symbol, indicates that this appliance/fitting may not be treated as household waste. Instead it shall be handed over to the applicable collection point for the recycling of electrical and electronic equipment. Disposal must be carried out in accordance with local environmental regulations for waste disposal. For more detailed information about treatment, recovery and recycling of this product, please contact your local authority, your household waste disposal service or the retailer where you purchased the product.